

USN

--	--	--	--	--	--	--	--	--	--

Seventh Semester B.E. Degree Examination, July/August 2022 Quantity Surveying and Contract Management

Time: 3 hrs.

Max. Marks: 100

Note: Answer any FIVE full questions, choosing ONE full question from each module.

Module-1

- 1 The plan and section details of a building is shown in Fig. Q1. Extract the quantities and prepare a abstract of estimate for the following item of work.
- Earthwork in excavation @ Rs 300/m³.
 - Cement concrete 1:4:8 for foundation @ Rs 4800/m³.
 - Size Stone Masonry in CM 1: 8 for foundation @ Rs 4000/m³.
 - Size Stone Masonry in CM 1 : 6 for basement @ Rs 4500/m³.
 - Burnt Brick Masonry for super structure in CM 1: 6 @ Rs 5200/m³.
- (20 Marks)**

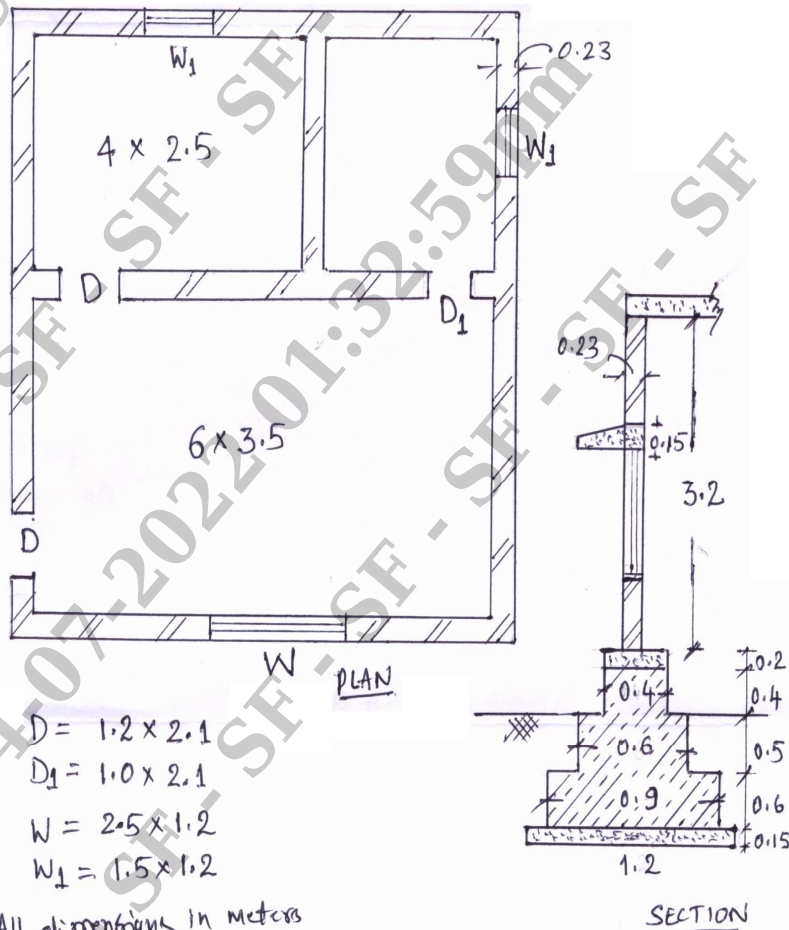

Fig. Q1.

Important Note : 1. On completing your answers, compulsorily draw diagonal cross lines on the remaining blank pages.
2. Any revealing of identification, appeal to evaluator and /or equations written eg. 42+8 = 50, will be treated as malpractice.

OR

- 2 a. List the types of estimates and explain briefly any two types of estimate. (08 Marks)
- b. A R.C.C beam 200mm × 300mm in section is of length 3.0m as shown in Fig. Q2(b). Steel bars 3 Nos 16mm diameter (weight = 1.58 kg/m), two outer bars straight and the inner bar bent up @ 45° as shown in Figure. At top two hanger rods of 10mm diameter (weight = 0.62 kg/m) are provided. Stirrups are 6mm diameter (weight = 0.22 kg/m). Cover to reinforcement @ all sides is 25mm. Estimate the quantities of civil items involved in the work. (12 Marks)

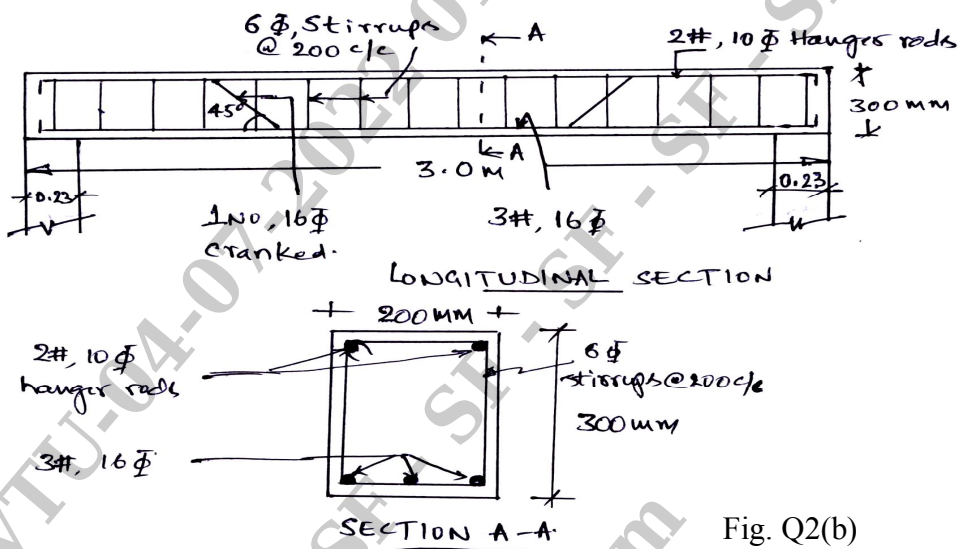

Fig. Q2(b)

Module-2

- 3 The details of Septic tank is given in Fig. Q3. Find the quantities of the following items of works.
- Earth work excavation for foundation in hard soil.
 - P.C.C for bottom of Septic tank.
 - Burnt Brick Masonry CM 1 : 4 for side walls.
 - Providing R.C.C. for slab.
 - Plastering to inner walls.

(20 Marks)

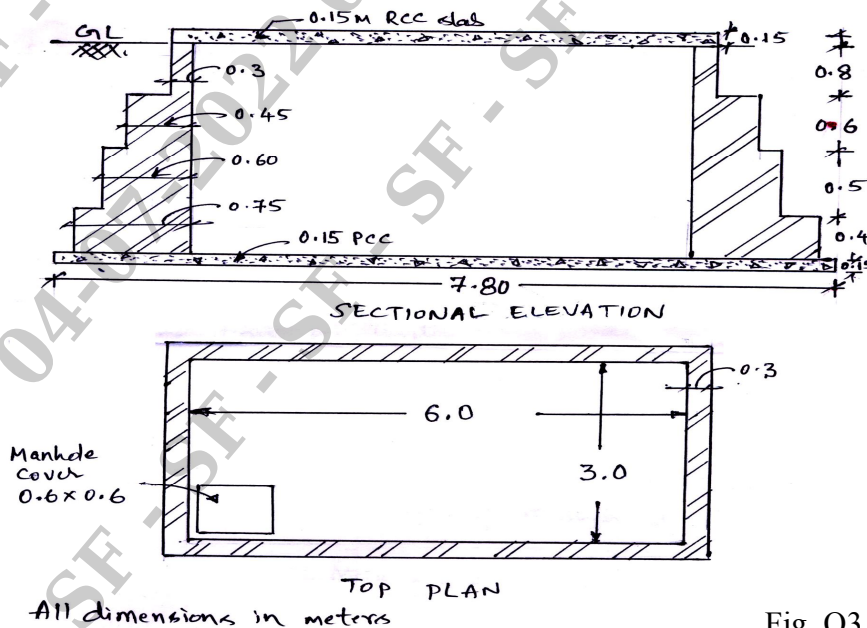

Fig. Q3



OR

- 4 Prepare an estimate of Earth work at the rate of Rs 150/cmtr for the data given below. Take formation width as 10m and slopes of banking as 2 : 1, length of each chain is 30m. Find also the area of side slopes and cost of turting at Rs 100/smtr.

Chainage	10	11	12	13	14	15	16	17	18	19	20
R.L of Ground	105.00	105.60	105.44	105.90	105.43	104.30	105.0	104.10	104.62	104.00	103.30
R.L of Formation	107.00	← Gradient 1 in 150 →				← Gradient 1 in 100 →					

(20 Marks)

Module-3

- 5 Explain detailed specifications for the following items of work :

- Earth work in excavation for foundation.
- Burnt Brick masonry in CM 1 : 6 for super structure.
- Cement concrete for Roof slab in 1 : 2 : 4.
- Cement plastering in CM 1 : 4.

(20 Marks)

OR

- 6 Workout from first principles, the rate analysis for the following items per unit.

- Size stone masonry in foundation in CM 1: 6.
- Providing and laying cement concrete 1 : 2 : 4 for flooring.
- 12mm thick plastering for walls in CM 1 : 4.
- First class brick masonry for super structure in CM 1 : 6.

(20 Marks)

Module-4

- 7 a. What is Tender and explain the procedure of invitation to tender or tender notice? (08 Marks)
b. Mention the different types of contracts and explain briefly any two types of contracts. (12 Marks)

OR

- 8 Explain briefly any FOUR of the following :

- Earnest Money Deposit and Security Deposit.
- Letter of Intent.
- Engineering Procurement Construction and Build , Operate and Transfer (BOT).
- Breach of Contract.
- FIDIC contract forms.

(20 Marks)

Module-5

- 9 Explain briefly any FOUR of the following :

- Mobilization and Equipment advances.
- Measurement and payment.
- Cost escalation.
- Additions and Alterations.
- Delays and Compensation.

(20 Marks)

OR

- 10 a. Define : i) Outgoings ii) Salvage Value iii) Sinking Fund iv) Obsolescence. (04 Marks)
b. What is Valuation? Explain different methods of valuation of buildings briefly. (16 Marks)

* * * * *